

Cirque - Cirque collection

design Bartoli Design



— Brushed matt lacquered or completely wood veneered units available in three different dimensions and with shelves and drawers in polished steel, “liquid fabric” or “crystal” finish. The low unit is fitted with a drawer; the medium unit with a hinged door and 3 fixed internal shelves and the high unit with a hinged door and 4 fixed internal shelves.

— Contenitori laccati opaco spazzolato o completamente impiallacciati in legno disponibili in 3 diverse dimensioni e con la stessa finitura interna ed esterna. Il contenitore più basso è dotato di un cassetto, quello medio di anta battente e 3 ripiani interni fissi e quello alto di anta battente e 4 ripiani interni fissi.



Cirque - Cirque collection

design Bartoli Design



— Totem-like furniture, resembling essential architectures, with a major and sculptural impact arousing a new and mysterious scenario. Cirque Collection products create an unexpected atmosphere, slight disorientation; when juxtaposed, similar to metaphysical objects, they produce an effect of suspension which stands out for its shapes, unusual when compared to the furniture we are used to.

— I contenitori Cirque hanno una forma che richiama quella dei totem, dal forte impatto visivo, e creano un nuovo e misterioso scenario. I prodotti della collezione Cirque danno vita a un'atmosfera unica e, quando giustapposti, creano un leggero disorientamento. In modo simile ad oggetti metafisici, questi prodotti producono un effetto di sospensione, inusuale se comparato ai mobili ai quali siamo normalmente abituati.

_dimensions

CQ 103 storage unit - mobile contenitore -
behältermöbel - meuble conteneur - Шкаф

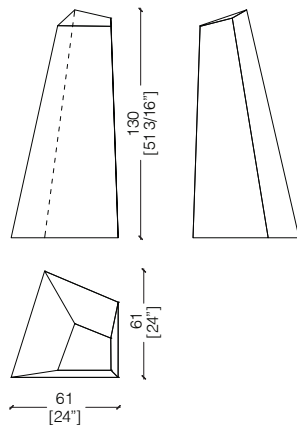

CQ 105 storage unit - mobile contenitore -
behältermöbel - meuble conteneur - Шкаф

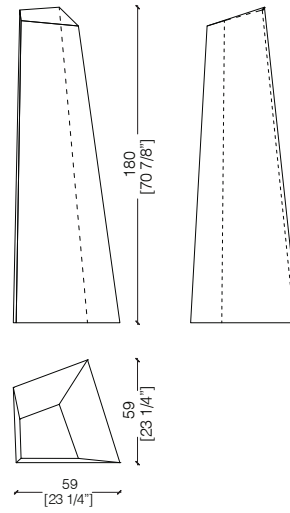

CQ 101 storage unit - mobile contenitore -
behältermöbel - meuble conteneur - Шкаф

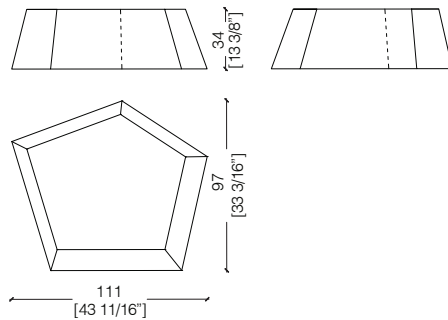

Dimensions in centimeters and inches.

The right to discontinue and make changes is reserved.

This information is based on the latest product information available at the time of printing.

_materials & finishes

plain woods



Maple



Oak



Teak



Zebrano



Canaletto Walnut

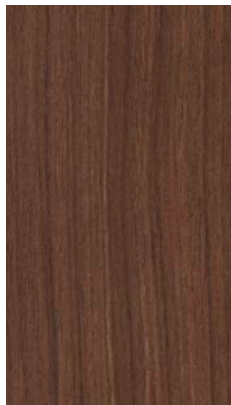

Dyed Canaletto walnut



Ebony



Termocotto Oak



Rosewood



Wenge



Mahogany

_The finishes shown are indicative and refer to the entire production range.
Laurameroni reserves the right to modify the range without warning.

_materials & finishes

dyed woods



Titanium AL1105



Grey AL1106



Sand AL1851



Black AL1853



Aniline dyed



Available in all
RAL / NCS colors

_The finishes shown are indicative and refer to the entire production range.
Laurameroni reserves the right to modify the range without warning.

_materials & finishes

lacquering



Brushed matt lacquered



Available in all
RAL / NCS colors

_materials & finishes

crystal



White Crystal

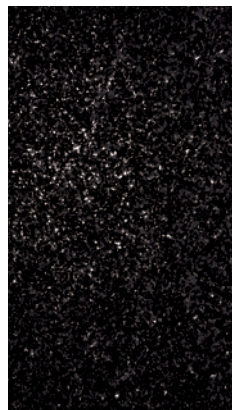

Black Crystal

_The finishes shown are indicative and refer to the entire production range.
Laurameroni reserves the right to modify the range without warning.

_materials & finishes

metal



Polished Steel

_The finishes shown are indicative and refer to the entire production range.
Laurameroni reserves the right to modify the range without warning.

— materials & finishes

liquid velvets



Liquid velvet
"nocciola beige"



Liquid velvet
"testa di moro"



Liquid velvet
"nero melange"



Liquid velvet
"canna di fucile"

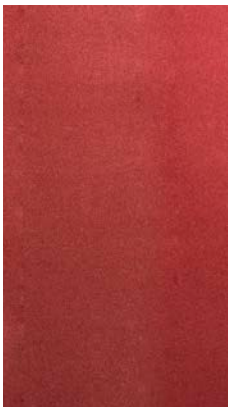

Liquid velvet
"rosso borgogna"

— The finishes shown are indicative and refer to the entire production range.
Laurameroni reserves the right to modify the range without warning.

_maintenance

**PAINTS, LACQUERINGS AND
SPECIAL FINISHES**

Do not use acid or alkaline detergents, agents with bleaching additives, abrasive powders, steel wool, sponges or the like. Do not use furniture polish or solvents to care for painted surfaces. Anything hot or humid can cause surface damage. Pointed or sharp objects, such as blades or knives, can cause damage to the surface. For the cleaning and care, regularly wipe the surfaces with a clean, soft, lint-free cloth to remove dust while avoiding abrasion. For soft-finish painted surfaces, use a soft, lint-free, slightly damp cloth. If heavily soiled, painted surfaces can be cleaned with a neutral, silicone-free detergent. Finally, it is essential to gently rub dry surfaces, so that there is no residual moisture.

**TINTE, LACCATURE E FINITURE
SPECIALI**

Non usare detergenti acidi o alcalini, agenti con additivi sbiancanti, polveri abrasive, lana d'acciaio, spugne o simili. Non utilizzare lucidi per mobili o solventi per la cura delle superfici verniciate. Qualsiasi cosa calda o umida può causare danni alla superficie. Oggetti appuntiti o taglienti, come lame o coltelli, possono causare danni alla superficie. Per la pulizia e la cura, pulire regolarmente le superfici con un panno pulito, morbido e privo di lanugine per rimuovere la polvere evitando l'abrasione. Per le superfici verniciate con finitura morbida, utilizzare un panno soffice, privo di lanugine e leggermente umido. Se molto sporche, le superfici verniciate possono essere pulite con un detergente neutro privo di silicone. È infine essenziale strofinare gentilmente le superfici asciutte, in modo che non sussista umidità residua.

_maintenance

WOOD

To maintain the natural wood features and protect them from mechanical and chemical wear, the veneered surfaces are coated with a high-quality transparent varnish. Do not use acid or alkaline detergents, agents with bleaching additives, abrasive powders, steel wool, sponges or the like. Anything hot or humid can cause surface damage. Remove dirt and liquids immediately.

For the cleaning and care, it is best to use a soft, dry cloth. If necessary, the cloth can be slightly dampened and dipped in neutral detergent thoroughly diluted in water. The cloth should only be slightly damp to avoid discoloration or swelling of the surface. Finally, it is essential to gently rub dry surfaces, so that there is no residual moisture.

LEGNO

Per mantenere il carattere naturale del legno e proteggerlo dall'usura meccanica e chimica, le superfici impialacciate sono rivestite con una vernice trasparente di alta qualità. Non usare detergenti acidi o alcalini, agenti con additivi sbiancanti, polveri abrasive, lana d'acciaio, spugne o simili. Qualsiasi cosa calda o umida può causare danni alla superficie. Rimuovere immediatamente sporco e liquidi. Per la pulizia e la cura, è preferibile utilizzare un panno morbido e asciutto. Eventualmente il panno può essere leggermente inumidito ed intinto in detergente neutro abbondantemente diluito in acqua. Il panno deve essere solo leggermente umido, per evitare scolorimenti o rigonfiamenti della superficie. È infine essenziale strofinare gentilmente le superfici asciutte, in modo che non sussista umidità residua.

**BEDIF
FEREN
TBEUN
IQUE.**

LAURAMERONI s.r.l.
22040 Alzate Brianza (Como)
Via Manzoni, 2784
T +39 031 761450
info@laurameroni.com
www.laurameroni.com