

Tray - Tray collection

design Romani Saccani Architetti Associati



Family of tables with tubular base in acid-etched metal with a “tray” effect, available in different shapes, designs and sizes, and customizable in the finishes.

Top available in all the woods of the collection, in special finishes, in marble and in back-lacquered glass.

Famiglia di tavolini con base tubolare in metallo acidato ad effetto “vassoio”, disponibili in diverse forme, design e dimensioni, e personalizzabili nelle finiture.

Piano disponibile in tutti i legni della collezione, in finiture speciali, in marmo ed in vetro retrolaccato.



_dimensions

RS 21 coffee table - tavolino
niedriger tisch - table basse - Журнальный столик

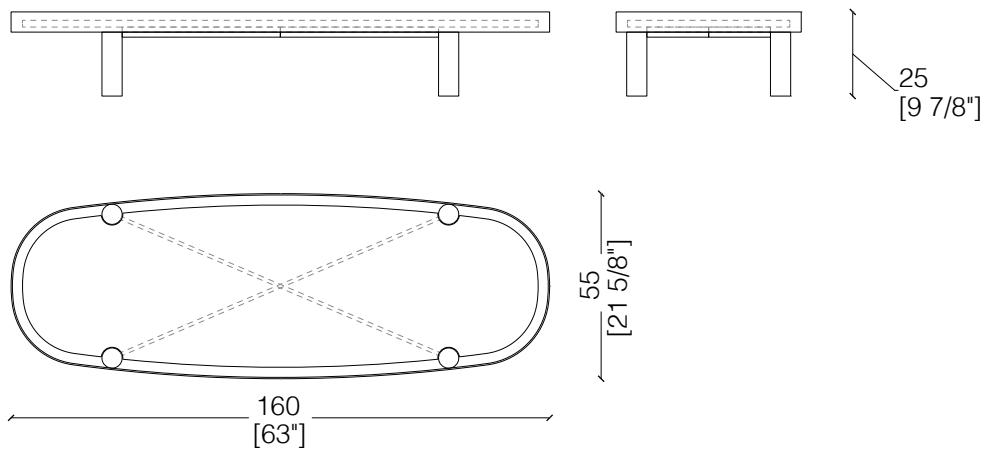

RS 22 coffee table - tavolino
niedriger tisch - table basse - Журнальный столик

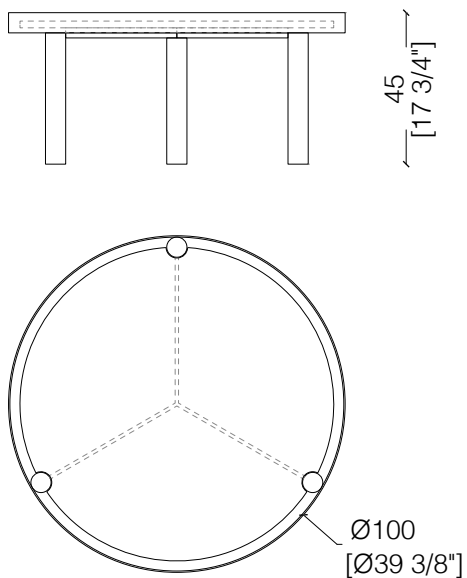

-Dimensions in centimeters and inches.
The right to discontinue and make changes is reserved.
This information is based on the latest product information available at the time of printing.

_dimensions

RS 23 coffee table - tavolino
niedriger tisch - table basse - Журнальный столик

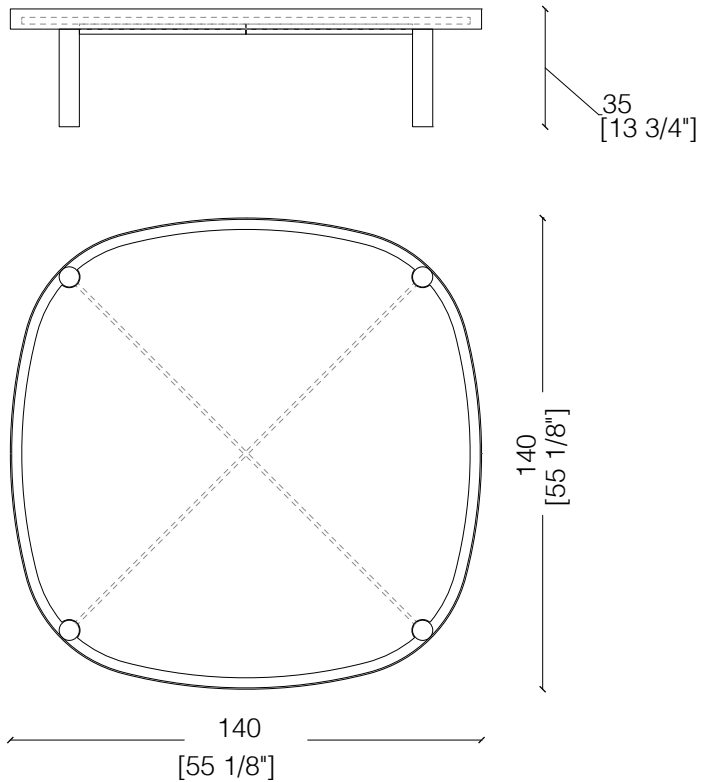

-Dimensions in centimeters and inches.
The right to discontinue and make changes is reserved.
This information is based on the latest product information available at the time of printing.

_dimensions

RS 24 coffee table - tavolino
niedriger tisch - table basse - Журнальный столик

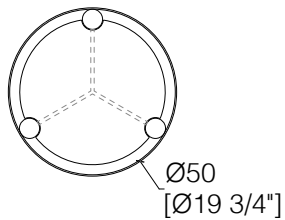
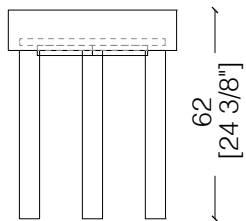

-Dimensions in centimeters and inches.
The right to discontinue and make changes is reserved.
This information is based on the latest product information available at the time of printing.

_materials and finishes for the structure

metal



Storm Etched Metal

_The finishes shown are indicative and refer to the entire production range.
Laurameroni reserves the right to modify the range without warning.

_materials & finishes for the top
plain woods



Maple



Oak



Teak



Zebrano



Walnut Canaletto



Dyed Walnut Canaletto



Mahogany



Ebony



"Termocotto" Oak



Rosewood



Wenge

_The finishes shown are indicative and refer to the entire production range.
Laurameroni reserves the right to modify the range without warning.

— materials and finishes for the top
dyed woods



Titanium AL1105



Grey AL1106



Sand AL1851



Black AL1853



Aniline Dyed



Available in all RAL
colours

— The finishes shown are indicative and refer to the entire production range.
Laurameroni reserves the right to modify the range without warning.

_materials & finishes

special woods



Stone Oak 'Carbone'



Stone Oak 'Tabacco'



'Faggio Antico'



Syberian Ash



Rosewood 'India'



Rosewood 'Santos'

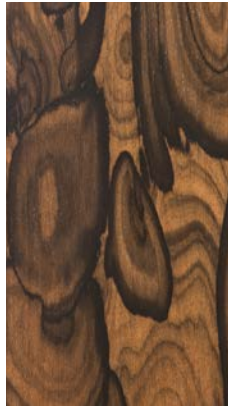

Ziricote

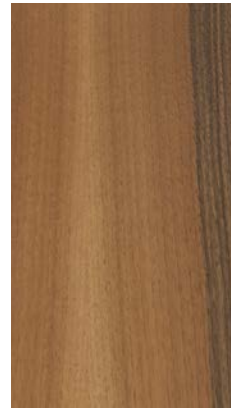

Walnut 'Colore'

_The finishes shown are indicative and refer to the entire production range.
Laurameroni reserves the right to modify the range without warning.

_materials & finishes for the top

back-painted glass

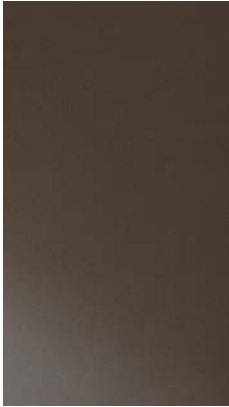

Back-painted glass
Bronze



Back-painted glass Tin

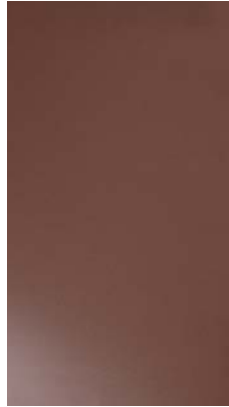

Back-painted glass
Copper

_materials & finishes for the top

marble

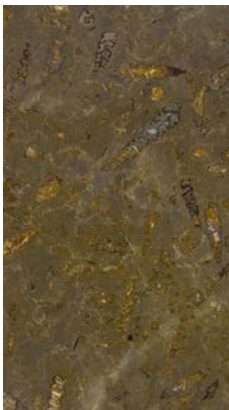

Alambra Brown

_The finishes shown are indicative and refer to the entire production range.
Laurameroni reserves the right to modify the range without warning.

— materials and finishes for the top
special finishes



Garza Gold



Black Rye-straw

— The finishes shown are indicative and refer to the entire production range.
Laurameroni reserves the right to modify the range without warning.

_maintenance

METAL & LIQUID METAL

To maintain the natural features of the metal and to protect the specific craftsmanship from oxidation and discoloration, the metal surfaces are coated with a high-quality transparent varnish. Do not use acid cleaners, solvents or alkalis. Do not use abrasive agents, steel wool, pot cleaners, glass cleaners, aggressive solvents, dyes, bleach or the like. Pointed or sharp objects, such as blades or knives, can cause damage to the surface. Anything hot or humid can cause surface damage.

For cleaning and care, remove light dirt with a soft cloth and a neutral household cleaning product well diluted in water. Gently clean the metal parts by hand with cold or warm water and dry immediately with a soft cloth.

METALLO & METALLO LIQUIDO

Per mantenere il carattere naturale del metallo e tutelare la specifica lavorazione artigianale da ossidazione e scolorimento, le superfici metalliche sono rivestite con una vernice trasparente di alta qualità.

Non utilizzare detergenti acidi, solventi o alcali. Non usare agenti abrasivi, lana d'acciaio, detergenti per pentole, detergenti per vetri, solventi aggressivi, coloranti, candeggina o simili. Oggetti appuntiti o taglienti, come lame o coltelli, possono causare danni alla superficie. Qualsiasi cosa calda o umida può causare danni alla superficie.

Per la pulizia e la cura, rimuovere lo sporco leggero con un panno morbido ed un prodotto neutro per la pulizia della casa abbondantemente diluito in acqua.

Pulire delicatamente a mano le parti metalliche con acqua fredda o tiepida ed asciugare immediatamente con un panno morbido.

_maintenance

_WOOD

To maintain the natural wood features and protect them from mechanical and chemical wear, the veneered surfaces are coated with a high-quality transparent varnish. Do not use acid or alkaline detergents, agents with bleaching additives, abrasive powders, steel wool, sponges or the like. Anything hot or humid can cause surface damage. Remove dirt and liquids immediately.

For the cleaning and care, it is best to use a soft, dry cloth. If necessary, the cloth can be slightly dampened and dipped in neutral detergent thoroughly diluted in water. The cloth should only be slightly damp to avoid discoloration or swelling of the surface. Finally, it is essential to gently rub dry surfaces, so that there is no residual moisture.

_LEGNO

Per mantenere il carattere naturale del legno e proteggerlo dall'usura meccanica e chimica, le superfici impiallacciate sono rivestite con una vernice trasparente di alta qualità. Non usare detergenti acidi o alcalini, agenti con additivi sbiancanti, polveri abrasive, lana d'acciaio, spugne o simili. Qualsiasi cosa calda o umida può causare danni alla superficie. Rimuovere immediatamente sporco e liquidi. Per la pulizia e la cura, è preferibile utilizzare un panno morbido e asciutto. Eventualmente il panno può essere leggermente inumidito ed intinto in detergente neutro abbondantemente diluito in acqua. Il panno deve essere solo leggermente umido, per evitare scolorimenti o rigonfiamenti della superficie. È infine essenziale strofinare gentilmente le superfici asciutte, in modo che non sussista umidità residua.

_maintenance

**PAINTS, LACQUERINGS AND
SPECIAL FINISHES**

Do not use acid or alkaline detergents, agents with bleaching additives, abrasive powders, steel wool, sponges or the like. Do not use furniture polish or solvents to care for painted surfaces. Anything hot or humid can cause surface damage. Pointed or sharp objects, such as blades or knives, can cause damage to the surface. For the cleaning and care, regularly wipe the surfaces with a clean, soft, lint-free cloth to remove dust while avoiding abrasion. For soft-finish painted surfaces, use a soft, lint-free, slightly damp cloth. If heavily soiled, painted surfaces can be cleaned with a neutral, silicone-free detergent. Finally, it is essential to gently rub dry surfaces, so that there is no residual moisture.

**TINTE, LACCATURE E FINITURE
SPECIALI**

Non usare detersivi acidi o alcalini, agenti con additivi sbiancanti, polveri abrasive, lana d'acciaio, spugne o simili. Non utilizzare lucidi per mobili o solventi per la cura delle superfici verniciate. Qualsiasi cosa calda o umida può causare danni alla superficie. Oggetti appuntiti o taglienti, come lame o coltelli, possono causare danni alla superficie.
Per la pulizia e la cura, pulire regolarmente le superfici con un panno pulito, morbido e privo di lanugine per rimuovere la polvere evitando l'abrasione. Per le superfici verniciate con finitura morbida, utilizzare un panno soffice, privo di lanugine e leggermente umido. Se molto sporche, le superfici verniciate possono essere pulite con un detersivo neutro privo di silicone. È infine essenziale strofinare gentilmente le superfici asciutte, in modo che non sussista umidità residua.

_maintenance

MARBLE

Natural stones are easily damaged by acids, fats and oils. These liquids tend to penetrate natural stone and leave dark, light or opaque stains that can no longer be removed.

Do not use acid cleaners, solvents or alkalis. Do not use abrasive agents, steel wool, pot cleaners, glass cleaners, aggressive solvents, dyes, bleach or the like. Anything hot or humid can cause surface damage.

For the cleaning and care, protect the product from abrasion, moisture and other external influences to prevent long-term destruction of the surface. Dust the natural stone regularly with a soft, lint-free cloth. Remove dirt and liquids immediately using only neutral detergents.

MARMO

Le pietre naturali sono facilmente danneggiabili da acidi, grassi ed oli. Questi liquidi tendono a penetrare nella pietra naturale e lasciare macchie scure, chiare od opache che non possono più essere rimosse.

Non utilizzare detergenti acidi, solventi o alcali. Non usare agenti abrasivi, lana d'acciaio, detergenti per pentole, detergenti per vetri, solventi aggressivi, coloranti, candeggina o simili. Qualsiasi cosa calda o umida può causare danni alla superficie.

Per la pulizia e la cura, proteggere il prodotto dall'abrasione, dall'umidità e da altre influenze esterne per prevenire la distruzione a lungo termine della superficie. Spolverare la pietra naturale regolarmente con un panno morbido e privo di lanugine. Rimuovere immediatamente sporco e liquidi utilizzando solo detergenti neutri.

**BEDIF
FEREN
TBEUN
IQUE.**

LAURAMERONI s.r.l.
22040 Alzate Brianza (Como)
Via Manzoni, 2784
T +39 031 761450
info@laurameroni.com
www.laurameroni.com