

## Solidi

design by LAURAMERONI



—Sculptural elements collection in standard sizes, offered in cylinder, cube, sphere, cone, and parallelepiped forms. Customizable with a wide selection of materials, surfaces, and treatments.

—Collezione di elementi scultorei in misure standard, declinati nelle forme cilindro, cubo, sfera, cono e parallelepipedo.

Personalizzabile grazie a un'ampia selezione di materiali, superfici e trattamenti.



\_dimensions

PH sphere - sfera - sphère - sphäre - сфера

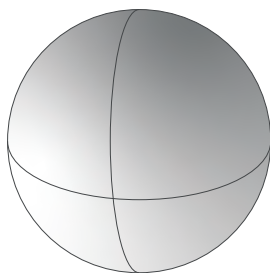
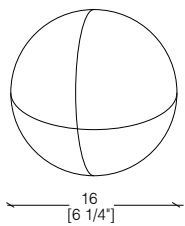

**Dimensions in millimeters and inches.**

**The right to discontinue and make changes is reserved.**

**This information is based on the latest product information available at the time of printing.**

\_materials & finishes

liquid velvet



Liquid velvet  
"nocciola beige"



Liquid velvet  
"testa di moro"



Liquid velvet  
"nero melange"



Liquid velvet  
"canna di fucile"



Liquid velvet  
"rosso borgogna"

\_The finishes shown are indicative and refer to the entire production range.  
Laurameroni reserves the right to modify the range without warning.

\_ materials & finishes

crystal



Cristal White



Cristal Black

\_ The finishes shown are indicative and refer to the entire production range.  
Laurameroni reserves the right to modify the range without warning.

\_dimensions

CO cone - cono - cône - kegel- конус

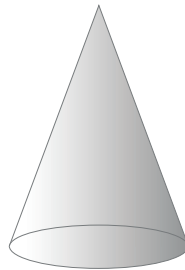
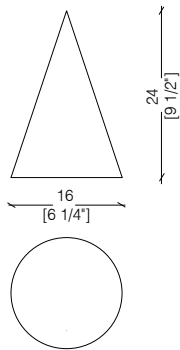

Dimensions in millimeters and inches.

The right to discontinue and make changes is reserved.

This information is based on the latest product information available at the time of printing.

\_materials & finishes

Raptor liquid metal



Liquid Metal Bronze



Liquid Metal Tin

\_materials & finishes for the top

marble



Nero Marquina

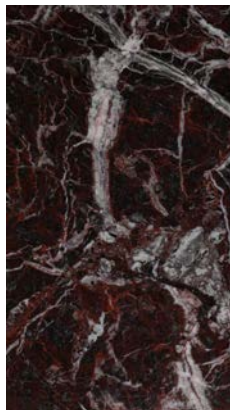

Levanto

\_The finishes shown are indicative and refer to the entire production range.  
Laurameroni reserves the right to modify the range without warning.

\_materials & finishes

rye straw



Black



Brown

\_materials & finishes

high gloss lacquered polyester



High Gloss Lacquered  
Polyester

\_The finishes shown are indicative and refer to the entire production range.  
Laurameroni reserves the right to modify the range without warning.

\_dimensions

CY cylinder - cilindro - cylindre - zylinder - цилиндр

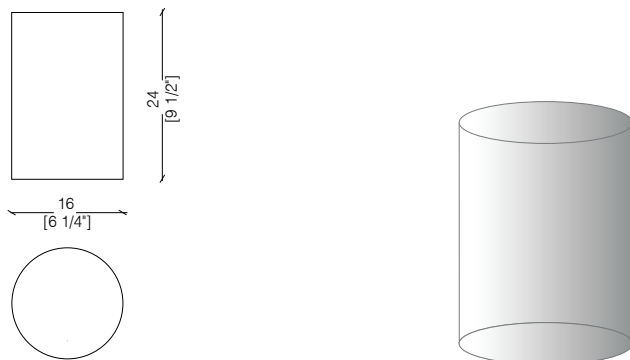

Dimensions in millimeters and inches.

The right to discontinue and make changes is reserved.

This information is based on the latest product information available at the time of printing.

\_materials & finishes

plain woods



Maple



Oak



Teak



Zebrano

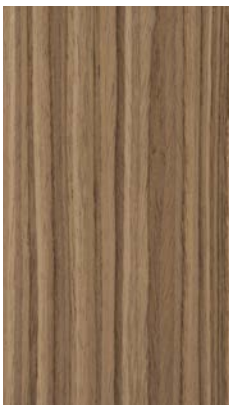

Walnut Canaletto



Dyed Walnut Canaletto



Mahogany



Ebony



Termocotto Oak



Rosewood



Wenge

\_The finishes shown are indicative and refer to the entire production range.  
Laurameroni reserves the right to modify the range without warning.

\_materials & finishes

dyed woods



Titanium AL1105



Grey AL1106



Sand AL1851



Black AL1853



Aniline dyed



Available in all  
RAL / NCS colours

\_The finishes shown are indicative and refer to the entire production range.  
Laurameroni reserves the right to modify the range without warning.

materials & finishes

special woods



Ziricote

The finishes shown are indicative and refer to the entire production range.  
Laurameroni reserves the right to modify the range without warning.

\_dimensions

**QU** cube - cubo - cube - würfel - ky6

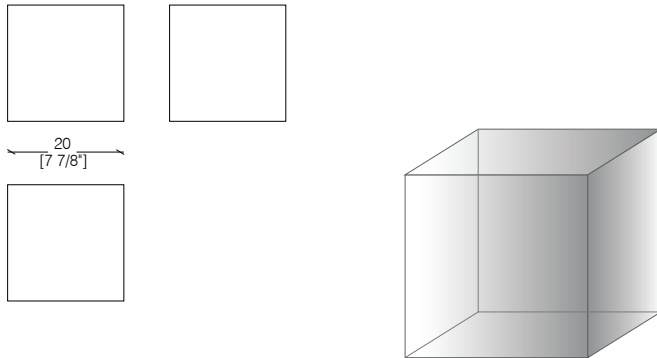

Dimensions in millimeters and inches.

The right to discontinue and make changes is reserved.

This information is based on the latest product information available at the time of printing.

materials & finishes

Onda woods



Maple Onda



Oak Onda



Teak Onda



Canaletto Walnut Onda



Rosewood Onda



Wengè Decor



Mahogany Onda



Anilina onda



Available in all RAL  
colours

The finishes shown are indicative and refer to the entire production range.  
Laurameroni reserves the right to modify the range without warning.

\_materials & finishes  
maxima carved woods



Maple Maxima



Oak Maxima



Teak Maxima



Canaletto Walnut Maxima



Rosewood Maxima



Wenge Maxima



Mahogany Maxima



Aniline Dyed Maxima



Available in all RAL  
colours

\_The finishes shown are indicative and refer to the entire production range.  
Laurameroni reserves the right to modify the range without warning.

\_materials & finishes  
maxima metallic varnish



Lacquered Bronze

\_The finishes shown are indicative and refer to the entire production range.  
Laurameroni reserves the right to modify the range without warning.

\_dimensions

**QU** paralelepiped - paralelepipedo - parallélépipède - paralelepiped - параллелепипед

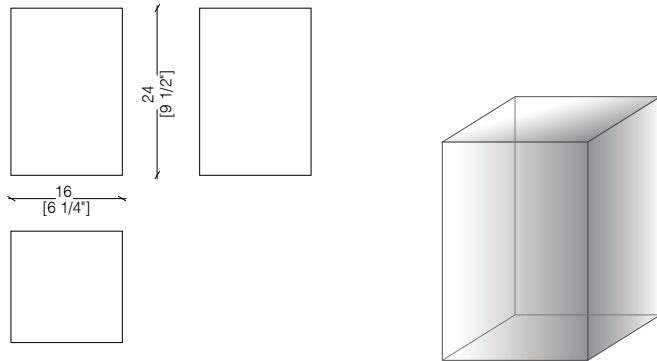

Dimensions in millimeters and inches.

The right to discontinue and make changes is reserved.

This information is based on the latest product information available at the time of printing.

— materials & finishes

tatami

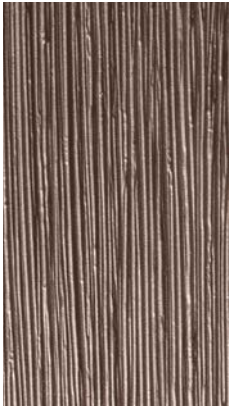

Bronze



Gold

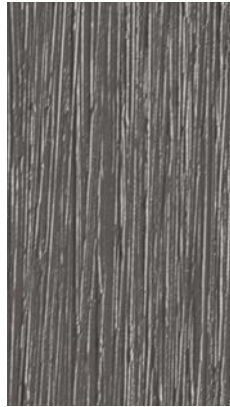

Nickel



Silver

— The finishes shown are indicative and refer to the entire production range.  
Laurameroni reserves the right to modify the range without warning.

\_materials & finishes

stars metals



**Burnished Copper**

\_materials & finishes

metals



**Oxidized Silver**

\_The finishes shown are indicative and refer to the entire production range.  
Laurameroni reserves the right to modify the range without warning.

\_maintenance

#### **LIQUID METALS**

To maintain the natural features of the metal and to protect the specific craftsmanship from oxidation and discoloration, the metal surfaces are coated with a high-quality transparent varnish. Do not use acid cleaners, solvents or alkalis. Do not use abrasive agents, steel wool, pot cleaners, glass cleaners, aggressive solvents, dyes, bleach or the like. Pointed or sharp objects, such as blades or knives, can cause damage to the surface. Anything hot or humid can cause surface damage.

For cleaning and care, remove light dirt with a soft cloth and a neutral household cleaning product well diluted in water. Gently clean the metal parts by hand with cold or warm water and dry immediately with a soft cloth.

#### **METALLO LIQUIDO**

Per mantenere il carattere naturale del metallo e tutelare la specifica lavorazione artigianale da ossidazione e scolorimento, le superfici metalliche sono rivestite con una vernice trasparente di alta qualità.

Non utilizzare detergenti acidi, solventi o alcali. Non usare agenti abrasivi, lana d'acciaio, detergenti per pentole, detergenti per vetri, solventi aggressivi, coloranti, candeggina o simili. Oggetti appuntiti o taglienti, come lame o coltelli, possono causare danni alla superficie. Qualsiasi cosa calda o umida può causare danni alla superficie.

Per la pulizia e la cura, rimuovere lo sporco leggero con un panno morbido ed un prodotto neutro per la pulizia della casa abbondantemente diluito in acqua.

Pulire delicatamente a mano le parti metalliche con acqua fredda o tiepida ed asciugare immediatamente con un panno morbido.

\_maintenance

**\_WOOD**

To maintain the natural wood features and protect them from mechanical and chemical wear, the veneered surfaces are coated with a high-quality transparent varnish. Do not use acid or alkaline detergents, agents with bleaching additives, abrasive powders, steel wool, sponges or the like. Anything hot or humid can cause surface damage. Remove dirt and liquids immediately.

For the cleaning and care, it is best to use a soft, dry cloth. If necessary, the cloth can be slightly dampened and dipped in neutral detergent thoroughly diluted in water. The cloth should only be slightly damp to avoid discoloration or swelling of the surface. Finally, it is essential to gently rub dry surfaces, so that there is no residual moisture.

**\_LEGNO**

Per mantenere il carattere naturale del legno e proteggerlo dall'usura meccanica e chimica, le superfici impiallacciate sono rivestite con una vernice trasparente di alta qualità. Non usare detergenti acidi o alcalini, agenti con additivi sbiancanti, polveri abrasive, lana d'acciaio, spugne o simili. Qualsiasi cosa calda o umida può causare danni alla superficie. Rimuovere immediatamente sporco e liquidi. Per la pulizia e la cura, è preferibile utilizzare un panno morbido e asciutto. Eventualmente il panno può essere leggermente inumidito ed intinto in detergente neutro abbondantemente diluito in acqua. Il panno deve essere solo leggermente umido, per evitare scolorimenti o rigonfiamenti della superficie. È infine essenziale strofinare gentilmente le superfici asciutte, in modo che non sussista umidità residua.

\_maintenance

#### **MARBLE**

**Natural stones are easily damaged by acids, fats and oils. These liquids tend to penetrate natural stone and leave dark, light or opaque stains that can no longer be removed.**

**Do not use acid cleaners, solvents or alkalis. Do not use abrasive agents, steel wool, pot cleaners, glass cleaners, aggressive solvents, dyes, bleach or the like. Anything hot or humid can cause surface damage.**

**For the cleaning and care, protect the product from abrasion, moisture and other external influences to prevent long-term destruction of the surface. Dust the natural stone regularly with a soft, lint-free cloth. Remove dirt and liquids immediately using only neutral detergents.**

#### **MARMO**

Le pietre naturali sono facilmente danneggiabili da acidi, grassi ed oli. Questi liquidi tendono a penetrare nella pietra naturale e lasciare macchie scure, chiare od opache che non possono più essere rimosse.

Non utilizzare detergenti acidi, solventi o alcali. Non usare agenti abrasivi, lana d'acciaio, detergenti per pentole, detergenti per vetri, solventi aggressivi, coloranti, candeggina o simili. Qualsiasi cosa calda o umida può causare danni alla superficie.

Per la pulizia e la cura, proteggere il prodotto dall'abrasione, dall'umidità e da altre influenze esterne per prevenire la distruzione a lungo termine della superficie. Spolverare la pietra naturale regolarmente con un panno morbido e privo di lanugine. Rimuovere immediatamente sporco e liquidi utilizzando solo detergenti neutri.

\_maintenance

**PAINTS, LACQUERINGS AND  
SPECIAL FINISHES**

To maintain the natural wood features and protect them from mechanical and chemical wear, the veneered surfaces are coated with a high-quality transparent varnish. Do not use acid or alkaline detergents, agents with bleaching additives, abrasive powders, steel wool, sponges or the like. Anything hot or humid can cause surface damage. Remove dirt and liquids immediately.

For the cleaning and care, it is best to use a soft, dry cloth. If necessary, the cloth can be slightly dampened and dipped in neutral detergent thoroughly diluted in water. The cloth should only be slightly damp to avoid discoloration or swelling of the surface. Finally, it is essential to gently rub dry surfaces, so that there is no residual moisture.

**TINTE, LACCATURE E FINITURE  
SPECIALI**

Non usare detergenti acidi o alcalini, agenti con additivi sbiancanti, polveri abrasive, lana d'acciaio, spugne o simili. Non utilizzare lucidi per mobili o solventi per la cura delle superfici verniciate. Qualsiasi cosa calda o umida può causare danni alla superficie. Oggetti appuntiti o taglienti, come lame o coltelli, possono causare danni alla superficie.

Per la pulizia e la cura, pulire regolarmente le superfici con un panno pulito, morbido e privo di lanugine per rimuovere la polvere evitando l'abrasione. Per le superfici verniciate con finitura morbida, utilizzare un panno soffice, privo di lanugine e leggermente umido. Se molto sporche, le superfici verniciate possono essere pulite con un detergente neutro privo di silicone. È infine essenziale strofinare gentilmente le superfici asciutte, in modo che non sussista umidità residua.

**BEDIF  
FEREN  
TBEUN  
IQUE.**

LAURAMERONI s.r.l.  
22040 Alzate Brianza (Como)  
Via Manzoni, 2784  
T +39 031 761450  
info@laurameroni.com  
www.laurameroni.com